

RACORES AUTOMATICOS PARA USO ALIMENTARIO F

Los materiales constituyentes de estos racores son adaptados por ser empleados también en la industria alimentaria. En efecto las partes en latón son tratadas con niquelado químico al fósforo, segundo el estándar NSF®/ANSI 51 del programa alimentario; las juntas son en FKM/FPM aprobado FDA. El racord no contiene piezas en tecnopolimero y, por eso, se evitan problemas de compatibilidad con detergentes y otros agentes químicos. Estas características de materiales permite el empleo del racord hasta 150°C y esto lo hace interesante también para otras aplicaciones, fuera del sector alimentario, donde exista una temperatura elevada.

Las roscas son cilíndricas con juntas de estanqueidad O-Ring bajo en cuerpo; esta solución evita el empleo de selladores (Teflón® o otros), que en fase de montaje y siguiente desmontaje podrían dejar fragmentos sólidos que perjudican el ambiente o el fluido; estos racores al contrario pueden ser atornillados cuantas veces se quiere garantizando siempre estanqueidad neumática y limpieza. Las características de los materiales y de los tratamientos pone estos racores interesantes también para aplicaciones en los sectores de la química, farmacéutica, médica, electrónica.

Se dispone de una gama de racores estándar pero, con petición, se puede realizar otras figuras.



DATOS TÉCNICOS

Roscas		M5 - G1/8" - G1/4" - G3/8" - G1/2"
Diámetros	mm	Ø4 - Ø6 - Ø8 - Ø10
Rango de temperaturas	°C	-20 ÷ +150
	°F	-4 ÷ 302
Rango de presión		-0,99 bar ÷ 16 bar / -0,099 MPa ÷ 1,6 MPa
Tubo recomendado		Rilsan PA11, Nylon 6, Poliamida 12, Polipropileno

COMPONENTES

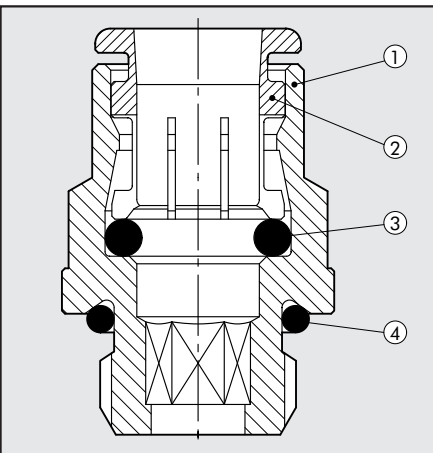

- ① Cuerpo: latón con niquelado químico según estándar NSF®/ANSI 51
- ② Pinza: latón con niquelado químico según estándar NSF®/ANSI 51
- ③ Juntas de estanqueidad en: FKM/FPM
- ④ Port seal: FKM/FPM

VENTAJAS

O Ring bajo cuerpo

Atornillar y desatornillar infinitamente ; ningún fragmento de Teflón® o sellador que pueda contaminar el fluido.

Resistencia a la corrosión

Niquelado químico + FKM/FPM son compatibles con muchísimas sustancias.

Ningún particular en plástico

Ningún riesgo de incompatibilidad





RECTO CILINDRICO MACHO R1 NSF

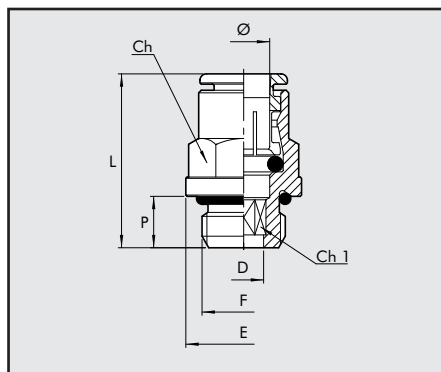

Cód.	Ref.	Ø	F	Ch	Ch1	P	L	D	E
2F01001	R1 NSF	4	M5	Ø9.9	2.5	4	21.5	2.6	9.9
2F01002	R1 NSF	4	1/8	11	3	6	20.5	3.1	15
2F01003	R1 NSF	4	1/4	12	3	8	22.5	3.1	18
2F01000	R1 NSF	6	M5	Ø12.9	2.5	4	25	2.6	12.9
2F01007	R1 NSF	6	1/8	13	4	6	27.5	4.2	15
2F01008	R1 NSF	6	1/4	13	4	8	26.5	4.2	18
2F01009	R1 NSF	8	1/8	14	5	6	28.5	5.2	15.6
2F01010	R1 NSF	8	1/4	15	6	8	27	6.2	18
2F01011	R1 NSF	8	3/8	15	6	9	28	6.2	21
2F01012	R1 NSF	10	1/4	17	7	8	33.5	7.2	20
2F01013	R1 NSF	10	3/8	17	8	9	30.5	8.2	21
2F01022	R1 NSF	10	1/2	17	10	11	31.5	10.2	26

RECTO CONICO MACHO RL1C NSF

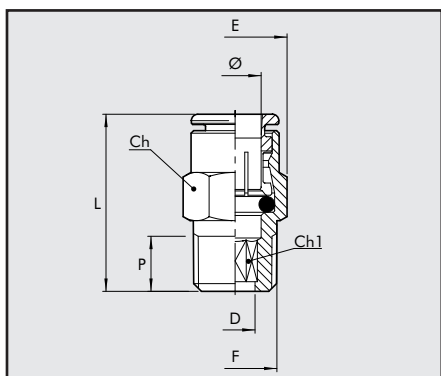

Cód.	Ref.	Ø	F	Ch	Ch1	P	L	D	E
2F01C02	RL1C NSF	4	1/8	10	2.5	6.2	20.5	3.1	11.5
2F01C07	RL1C NSF	6	1/8	12	4	6.2	24	4.2	13.8
2F01C08	RL1C NSF	6	1/4	14	4	8.5	25.5	4.2	16
2F01C09	RL1C NSF	8	1/8	14	5	6.2	27.5	5.2	16
2F01C10	RL1C NSF	8	1/4	14	6	8.5	27.5	6.2	16
2F01C11	RL1C NSF	8	3/8	17	6	9	27	6.2	19.6
2F01C13	RL1C NSF	10	1/4	17	7	8.5	34.5	7.2	19.6
2F01C14	RL1C NSF	10	3/8	17	7	9	30.5	7.2	19.6

RECTO HEMBRA R2 NSF

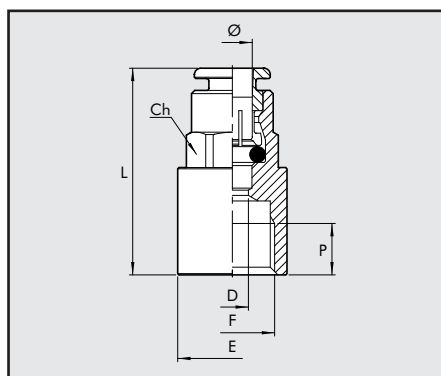

Cód.	Ref.	Ø	F	Ch	P	L	D	E
2F02001	R2 NSF	4	1/8	10	7	27	3	14
2F02005	R2 NSF	6	1/8	13	7	30	5	15
2F02006	R2 NSF	6	1/4	13	8	32	5	17
2F02007	R2 NSF	8	1/8	14	7	30	7	17
2F02008	R2 NSF	8	1/4	14	8	32	7	17
2F02011	R2 NSF	10	1/4	17	8	35	9	20

RECTO INTERMEDIO R3 NSF

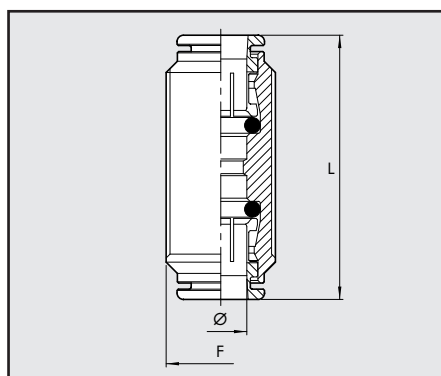

Cód.	Ref.	Ø	F	L
2F03001	R3 NSF	4	M13X1	33
2F03003	R3 NSF	6	M15X1	40
2F03004	R3 NSF	8	M17X1	41
2F03005	R3 NSF	10	M20X1	47

L INTERMEDIO R4 NSF

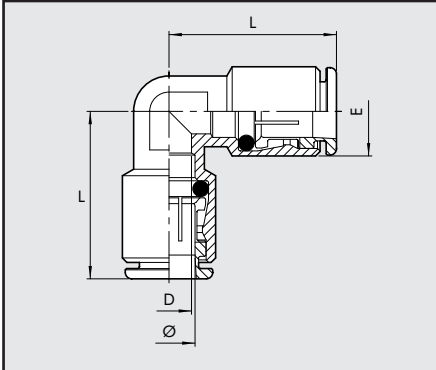

Cód.	Ref.	Ø	D	E	L
2F04001	R4 NSF	4	2.5	9.5	18
2F04003	R4 NSF	6	4.5	13.5	22
2F04004	R4 NSF	8	7	14	26
2F04005	R4 NSF	10	9	17	30

T INTERMEDIO R5 NSF

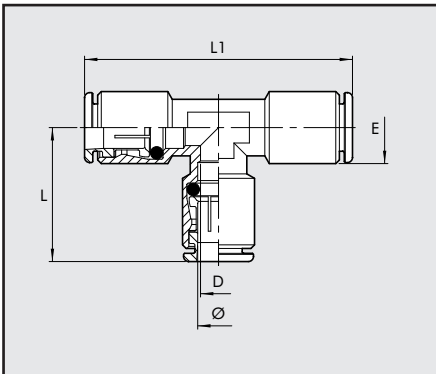

Cód.	Ref.	Ø	L	L1	D	E
2F05001	R5 NSF	4	21	42	3.5	9.5
2F05003	R5 NSF	6	24	48	5	12.5
2F05004	R5 NSF	8	26	52	7	14
2F05005	R5 NSF	10	30	60	9	17

ADAPTADOR ROSCADO R6 NSF

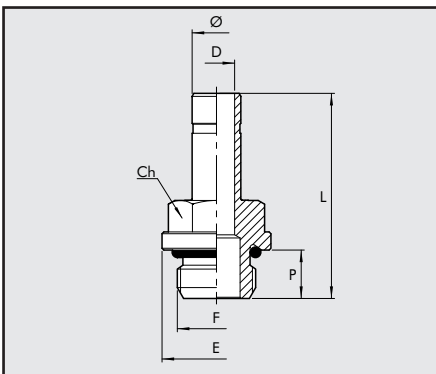

Cód.	Ref.	Ø	F	Ch	P	L	D	E
2F06001	R6 NSF	4	M5	8	4	25.2	2.5	9
2F06002	R6 NSF	4	1/8	13	6	28.9	2.5	15
2F06003	R6 NSF	4	1/4	14	8	32.4	2.2	18
2F06000	R6 NSF	6	M5	9	4	25.7	2.7	10
2F06007	R6 NSF	6	1/8	13	6	29.4	4	15
2F06008	R6 NSF	6	1/4	14	8	32.9	4	18
2F06009	R6 NSF	8	1/8	13	6	30.6	5.5	15
2F06010	R6 NSF	8	1/4	14	8	34	6	18
2F06011	R6 NSF	8	3/8	17	9	35.4	6	22
2F06012	R6 NSF	10	1/4	14	8	35.6	7.8	18
2F06013	R6 NSF	10	3/8	17	9	37.1	8	22

RECTO INTERMEDIO PASAMURO R10 NSF

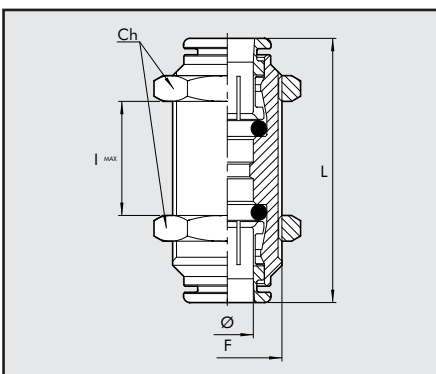

Cód.	Ref.	Ø	F	Ch	L	I_max
2F11001	R10 NSF	4	M13x1	16	33	11
2F11003	R10 NSF	6	M15x1	17	40	16
2F11004	R10 NSF	8	M17x1	20	41	19
2F11005	R10 NSF	10	M20x1	24	47	21



L MACHO CILINDRICO GIRATORIO R31 NSF

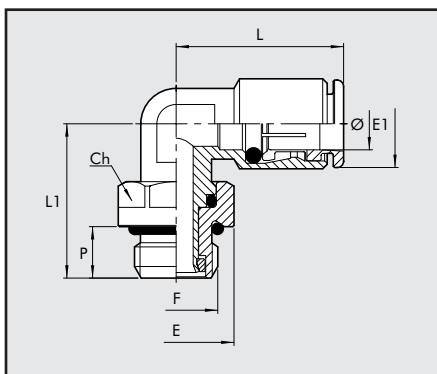

Cód.	Ref.	∅	F	Ch	E	E1	L	L1	P
2F31001	R31 NSF	4	M5	9	9	10	21	19	4
2F31002	R31 NSF	4	1/8	13	15	10	21	21	6
2F31003	R31 NSF	4	1/4	16	18	10	21	25	8
2F31007	R31 NSF	6	M5	9	8	11.8	24	17.5	4
2F31008	R31 NSF	6	1/8	13	15	12.5	24	21	6
2F31009	R31 NSF	6	1/4	16	18	12.5	25.5	25	8
2F31010	R31 NSF	8	1/8	13	15	14	26	22.5	6
2F31011	R31 NSF	8	1/4	16	18	14	26	25	8
2F31012	R31 NSF	8	3/8	19	22	14	27.5	30.5	9
2F31013	R31 NSF	10	1/4	16	18	16.5	30	27	8
2F31014	R31 NSF	10	3/8	19	22	16.5	30	30.5	9
2F31015	R31 NSF	10	1/2	22	26	16.5	31	32	11

L MACHO CONICO GIRATORIO R31C NSF

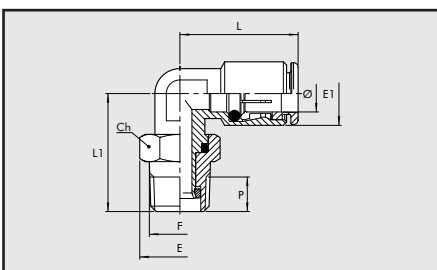

Cód.	Ref.	∅	F	Ch	E	E1	L	L1	P
2F31C02	R31C NSF	4	1/8	12	13.3	10	21	22	6.2
2F31C03	R31C NSF	4	1/4	16	17.7	10	21	27	8.5
2F31C08	R31C NSF	6	1/8	12	13.3	11.8	24	22	6.2
2F31C09	R31C NSF	6	1/4	16	17.7	12.5	25.5	27	8.5
2F31C10	R31C NSF	8	1/8	12	13.3	14	26	23.5	6.2
2F31C11	R31C NSF	8	1/4	16	17.7	14	26	27	8.5
2F31C12	R31C NSF	8	3/8	19	22	14	27.5	31	9
2F31C13	R31C NSF	10	1/4	16	17.7	16.5	30	29	8.5
2F31C14	R31C NSF	10	3/8	19	22	16.5	30	31	9

T CENTRAL MACHO CILINDRICO GIRATORIO R32 NSF

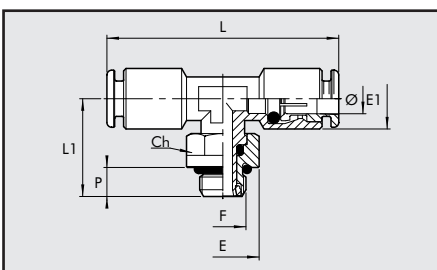

Cód.	Ref.	∅	F	Ch	E	E1	L	L1	P
2F32002	R32 NSF	4	1/8	13	15	10	41.5	21	6
2F32008	R32 NSF	6	1/8	13	15	12.5	47.5	21	6
2F32009	R32 NSF	6	1/4	16	18	12.5	50.5	25	8
2F32010	R32 NSF	8	1/8	13	15	14	52	22.5	6
2F32011	R32 NSF	8	1/4	16	18	14	52	25	8
2F32012	R32 NSF	8	3/8	19	22	14	56	30.5	9
2F32013	R32 NSF	10	1/4	16	18	16.5	60.5	27	8
2F32014	R32 NSF	10	3/8	19	22	16.5	60.5	30.5	9

T LATERAL MACHO CILINDRICO GIRATORIO R38 NSF

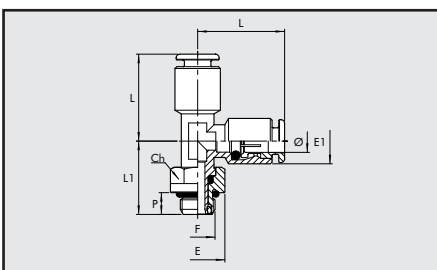

Cód.	Ref.	∅	F	Ch	E	E1	L	L1	P
2F38002	R38 NSF	4	1/8	13	15	9.5	22.5	21	6
2F38008	R38 NSF	6	1/8	13	15	12.5	24.5	21	6
2F38009	R38 NSF	6	1/4	16	18	12.5	26	25	8
2F38010	R38 NSF	8	1/8	13	15	14.5	27.5	22.5	6
2F38011	R38 NSF	8	1/4	16	18	14.5	27.5	25	8
2F38013	R38 NSF	10	1/4	16	18	17	31.5	27	8
2F38014	R38 NSF	10	3/8	19	22	17	31.5	30.5	9

L MACHO CONICO R39 NSF

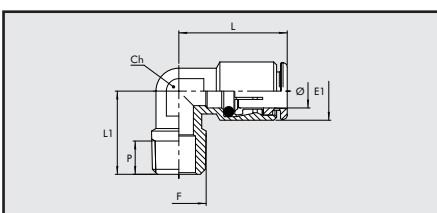

Cód.	Ref.	∅	F	Ch	E1	L	L1	P
2F39C02	R39 NSF	4	1/8	10	9.5	21	16	6.2
2F39C08	R39 NSF	6	1/8	10	11.8	23.5	16	6.2
2F39C09	R39 NSF	6	1/4	10	11.8	24	18.5	8.5
2F39C10	R39 NSF	8	1/8	12	14	26	17	6.2
2F39C11	R39 NSF	8	1/4	12	14	26	20	8.5
2F39C12	R39 NSF	8	3/8	14	14	27.5	22.5	9
2F39C13	R39 NSF	10	1/4	14	17	30.5	22	8.5